

**Typical Features**

- ◆ Wide input voltage range:85-265VAC/120-370VDC
- ◆ No-load power consumption≤0.5W
- ◆ Transfer efficiency 79%
- ◆ Switching frequency: 65KHz
- ◆ Output Short Circuit, Over Current, Over Voltage Protection
- ◆ Isolation voltage: 4000Vac
- ◆ Conform to IEC62368/UL62368/EN62368 test standard
- ◆ CE, RoHS approved
- ◆ Plastic case, meets flammability UL94 V-0
- ◆ PCB mounting, Chassis mounting, Din-rail mounting available



**Application Field**

**FA20-220H05XXXXH2D4(-T) (-TS) Series**----- a compact size, high efficient power converter offered by Aipu. It features universal input voltage, DC and AC dual-use, low ripple, low temperature rise, low power consumption, high efficiency, high reliability, safer isolation, good EMC performance. EMC and safety specifications meet EN55032, IEC/EN61000 standard. It widely used in power, industrial, instrument, smart home applications. For harsh EMC environment, the application circuit in the datasheet is strongly recommended.

**Typical Product List**

Certificate	Part No.	Output Specifications					Max Capacitive Load(Max)		Ripple& Noise 20MHz(Max)		Efficiency/full load 220V AC(Typ)
		Power	Vo1	Io1	Vo2/Vo3	Io2	Vo1	Vo2/Vo3	Vo1	Vo2/Vo3	
		(W)	(V)	(mA)	(V)	(mA)	uF	uF	mVp-p		
CE/RoHS	FA20-220H051515H2D4	20	5	2000	+/- 15	300	9000	470/470	80	200	79
CE/RoHS	FA20-220H051212H2D4	20	5	2000	+/- 12	400	9000	470/470	80	200	79

Note 1: Suffix"-T" means chassis mounting, "-TS" for Din-rail mounting, rail width 35mm.

Note 2: The typical output efficiency is based on that product is full loaded and burned-in after half an hour.

Note 3: Fluctuation range of full load efficiency(% ,TYP) is ±2%, full load output efficiency= total output power/module's input power.

**Input Specification**

Item	Operating Condition	Min.	Typ.	Max.	Unit
Input Voltage Range	AC Input	85	220	265	VAC
	DC Input	120	310	370	VDC
Input Frequency Range	-	47	50	63	Hz
Input Current	115VAC	/	/	0.35	A

	220VAC	/	/	0.175	
Surge Current	115VAC	/	25	/	
	220VAC	/	45	/	
No Load Power Consumption	115VAC	/	/	0.5	W
	230VAC	/	/		
Leakage Current	-	0.5mA TYP/230VAC/50Hz			
External fuse recommended value	-	2A-3.15A/250VAC slow-fusing			
Hot plug	-	Unavailable			
Remote control terminal	-	Unavailable			

**Output Specification**

Item	Operating Condition		Min.	Typ.	Max.	Unit
Voltage Accuracy	Full input voltage range Any load	Vo1	-	±1.0	±3.0	%
		Vo2/Vo3	-	-	±10.0	%
Line Regulation	Nominal Load	Vo1	-	-	±0.5	%
		Vo2/Vo3	-	-	±1.5	%
Load Regulation	Nominal input Voltage 20%~100% load	Vo1	-	-	±2.0	%
		Vo2/Vo3	-	-	±5.0	%
Minimum load	V01/V02		0	-	-	%
Turn-on Delay Time	Input 115Vac, full load		-	1500	-	mS
	Input 220Vac, full load		-	1000	-	
Power-off Holding Time	Input 115VAC (full load)		-	10	-	mS
	Input 220VAC (full load)		-	60	-	
Dynamic Response	25%~50%~25%		-5.0	-	+5.0	%
	50%~75%~50%		-5.0	-	+5.0	mS
Output Overshooting	Full input voltage range	Vo1	≤10%Vo			%
Short Circuit Protection		-	Continuous, Self-recovery			Hiccup
Drift Coefficient	-		-	±0.05%	-	%/°C
Over Current Protection	Input 220VAC(VO2) nominal load		≥150% Io, Self-recovery			Hiccup
Over Voltage Protection	Output Voltage	5VDC	≤7.5			VDC
Ripple & Noise	Vo1		-	50	80	mV
	Vo2		-	100	200	

It is tested by Twisted Pair Method, details please check "Ripple & Noise Test" at back of datasheet.

**General Specifications**

Item	Operating Condition	Min.	Typ.	Max.	Unit
Switching Frequency	-	-	65	-	KHz
Operating Temperature	-	-40	-	+70	°C
	Derating based on Temperature Derating Curve, see "Product Characteristic Curve" at back.				
Storage Temperature	-	-40	-	+85	
Soldering Temperature	Wave-soldering	260±4°C, timing 5-10S			
	Manual-soldering	360±8°C, timing 4-7S			
Relative Humidity	-	10	-	90	%RH
Isolation Voltage	I/P-O/P	Test 1min, leakage current ≤5mA	4000	-	VAC
	Vo1-Vo2	Test 1min, leakage current ≤5mA	500	-	VDC
Insulation Resistance	Input-Output@DC500V	100	-	-	MΩ
Safety Standard	-	IEC62368/EN62368/UL62368			
Vibration	-	10-55Hz,10G,30Min, along X,Y,Z			
Safety Class	-	CLASS I			
Class of Case Material	-	UL94 V-0			
MTBF	-	MIL-HDBK-217F@25°C > 300,000H			

**EMC Characteristics**

Total Item	Sub Item	Test Standard	Class		
EMC	EMI	CE	CISPR22/EN55032 CLASS B (see recommended circuit Photo 2)		
		RE	CISPR22/EN55032 CLASS B (see recommended circuit Photo 2)		
	EMS	RS	IEC/EN61000-4-3	10V/m Perf.Criteria B (see recommended circuit Photo 2)	
		CS	IEC/EN61000-4-6	3Vr.m.s Perf.Criteria B (see recommended circuit Photo 2)	
		ESD	IEC/EN61000-4-2	Contact ±6KV / Air ±8KV Perf.Criteria B	
		Surge	IEC/EN61000-4-5	Line to line ±1KV/ line to ground ±2KV	Perf.Criteria B
				Line to line ±2KV/ line to ground ±4KV	Perf.Criteria B (see recommended circuit Photo 2)
		EFT	IEC/EN61000-4-4	±2KV	Perf.Criteria B
				±4KV	Perf.Criteria B (see recommended circuit Photo 2)
		Voltage dips and interruptions	IEC/EN61000-4-11	0%~70%	Perf.Criteria B

**H2 Packing Dimension**

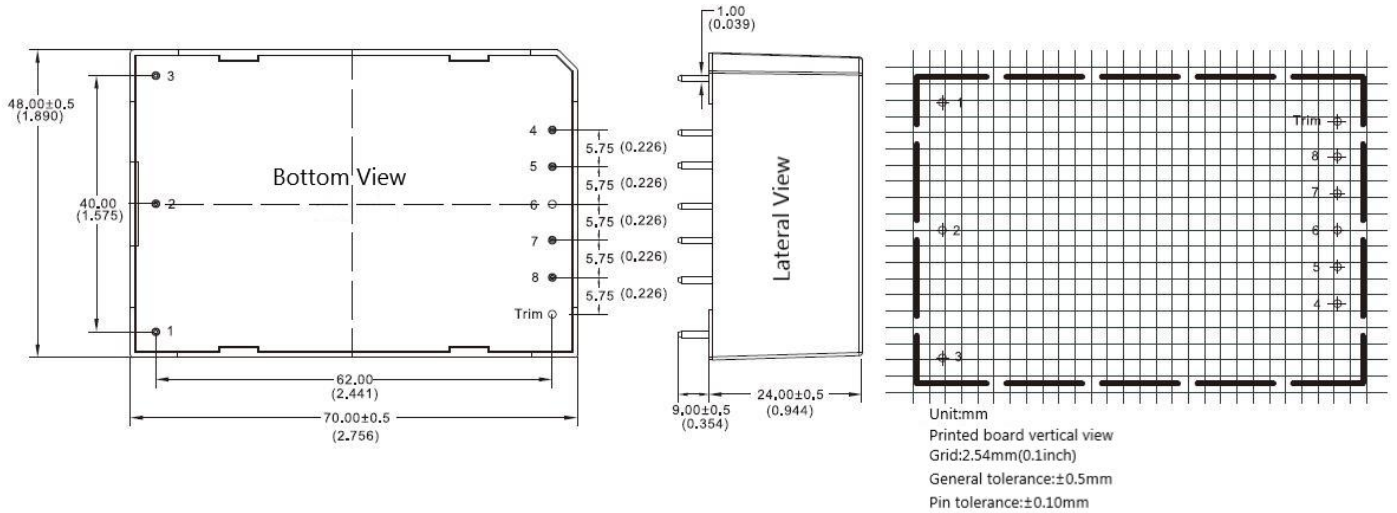

**H2-T Packing Dimension**

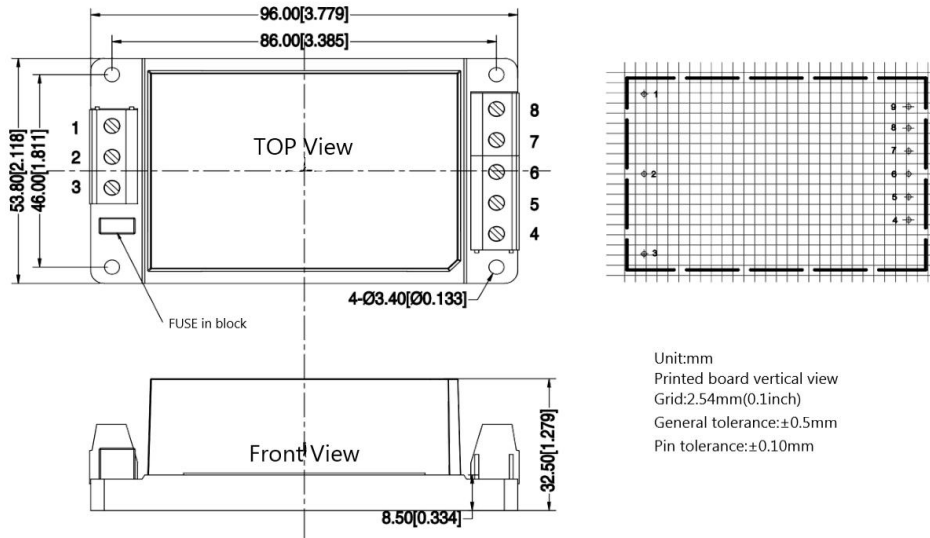

**H2-TS Packing Dimension**

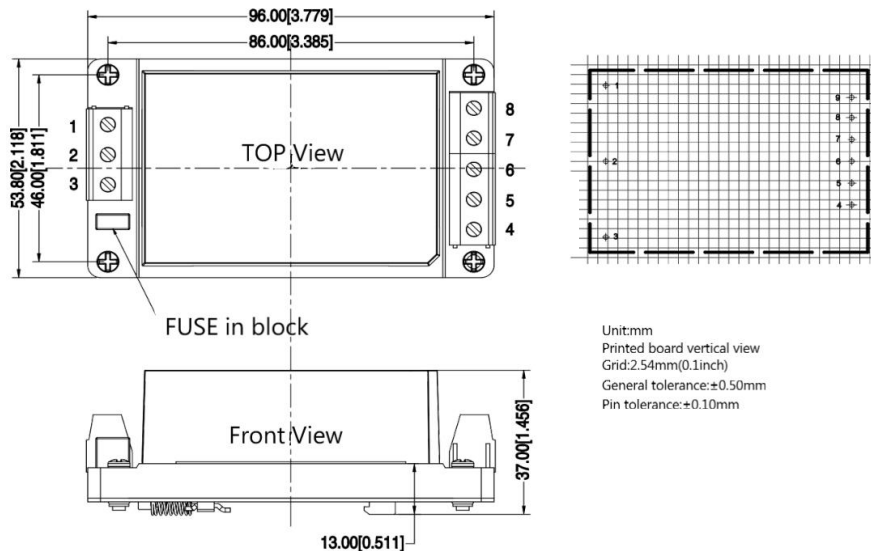

Packing Code	L x W x H	
H2	70.0 x 48.0 x 24.0 mm	2.756X1.890X0.945inch
H2-T	96.0X53.8X32.5 mm	3.780X2.118X1.280inch
H2-TS	96.0X53.8X37.0 mm	3.780X2.118X1.457inch

**Pin Definition**

Pin-out	1	2	3	4	5	6	7	8
Triple(H)	FG	AC(N)	AC(L)	+Vo2	COM	-Vo2	+Vo1	-Vo1

Note: If the definition of pin is not in accordance with the model selection manual, please refer to the label on actual item.

**Ripple & Noise Test: (Twisted Pair Method 20MHZ bandwidth)**

**Test Method:**

(1) 12# twisted pair to connect, Oscilloscope bandwidth set as 20MHZ, 100M bandwidth probe, terminated with 0.1uF polypropylene capacitor and 10uF high frequency low resistance electrolytic capacitor in parallel, oscilloscope set as Sample pattern.

(2) Input terminal connect to power supply, output terminal connect to electronic load through jig plate, Use 30cm±2 cm sampling line. Power line selected from corresponding diameter wire with insulation according to the flow of output current.

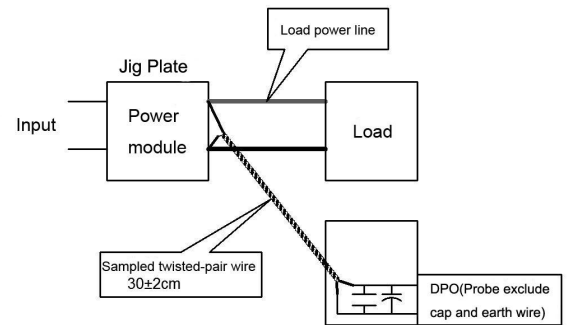

**Product Characteristic Curve**

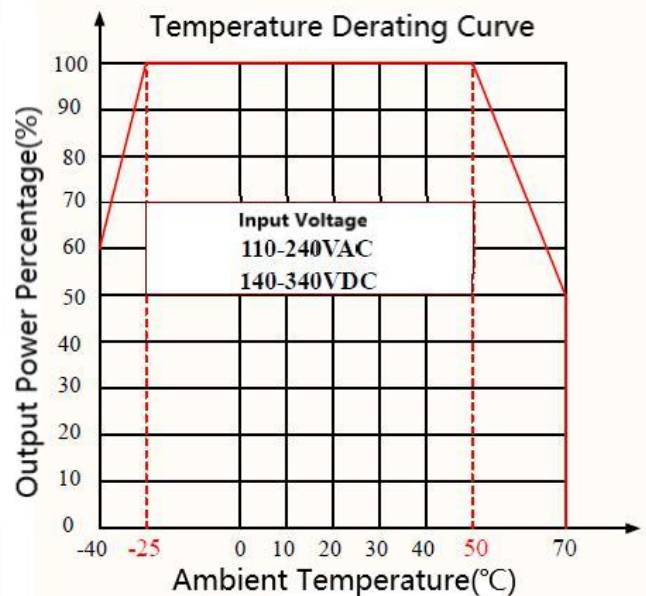
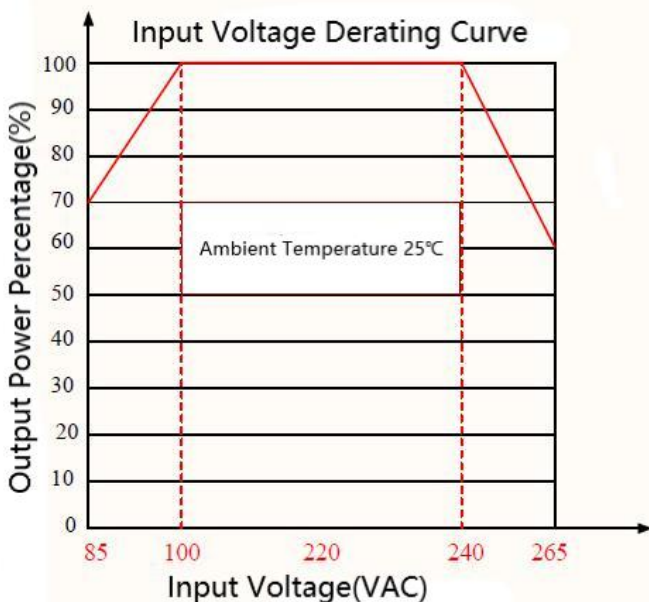

- Note
- 1: Input Voltage should be derated base on Input Voltage Derating Curve when it is 85~100VAC /240~265VAC /100~120VDC /340~370VDC.
  - 2: Our product is suitable to use under natural air cooling environment, if use it under closed condition, please contact with us.

**Typical EMC Circuit and Recommended Spec**

**1. Typical Application Circuit**

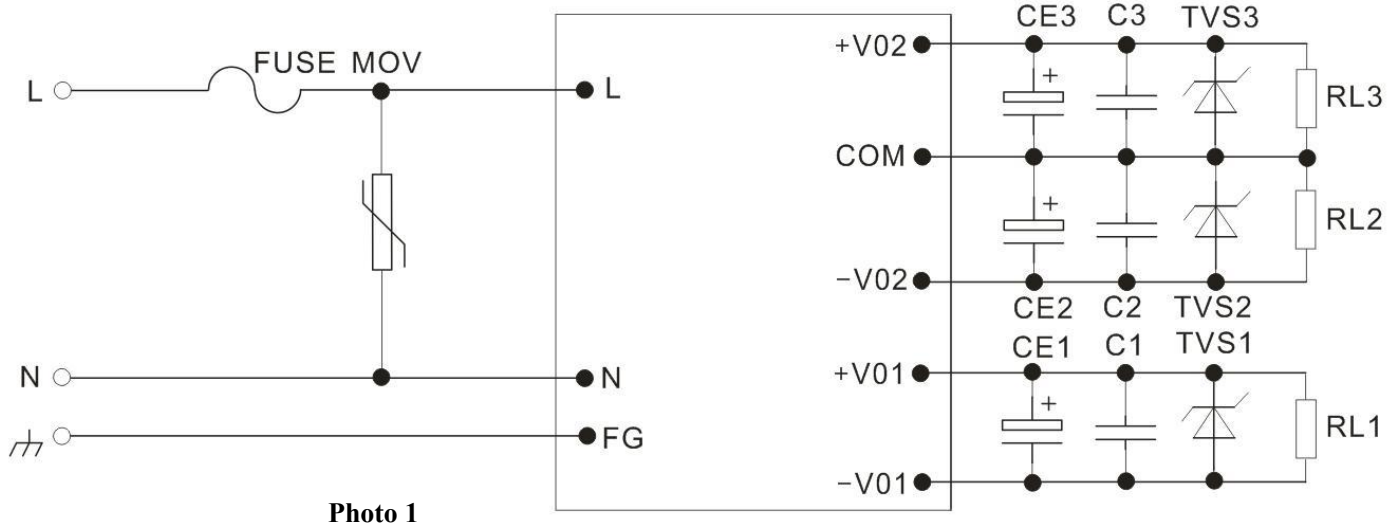

**Photo 1**

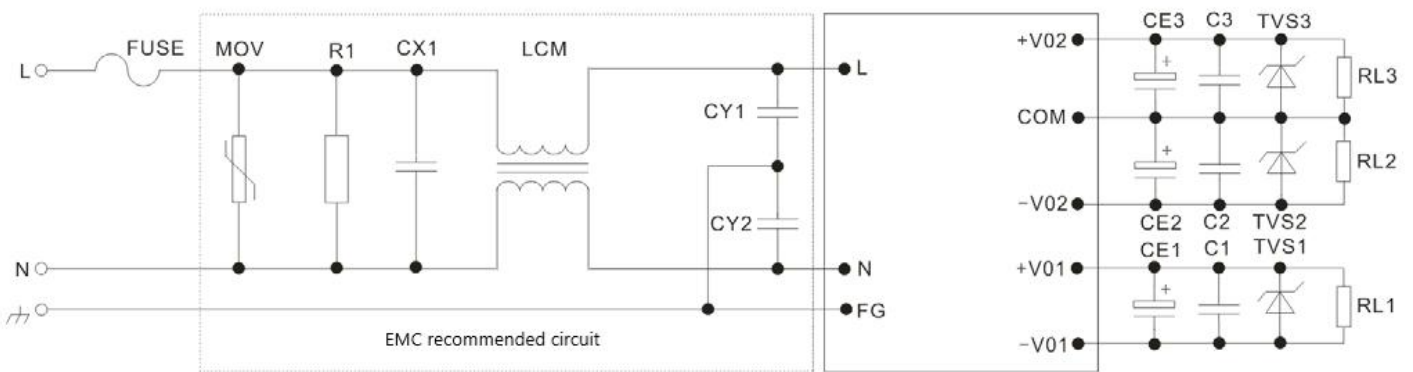

**Photo 2**

- 1) FUSE, necessary, recommended 2A/250Vac slow fusing;
- 2) MOV is voltage dependent resistor, recommended 14D561K, to prevent the module from damage when lightning surge.
- 3) Output filter capacitors CE1, CE2, CE3 are electrolytic capacitors, recommended to use high-frequency low-resistance ones, with a capacity of 100uF/1A output current. The capacitor withstand voltage derating is more than 80%.
- 4) The output filter capacitors C1, C2, C3 remove high-frequency noise, recommended to use 1μF ceramic capacitors, and the capacitor withstand voltage derating is greater than 80%.
- 5) TVS tube is recommended to protect the subsequent circuit (when the module is abnormal). 600W model is recommended. 5V output recommend: SMBJ7.0A, 9V output recommend: SMBJ12.0A, 12V output recommend: SMBJ20.0A, 15V output recommend: SMBJ20.0A, 24V output recommend: SMBJ30.0A, 48V output recommend: SMBJ64.0A.
- 6) For normal application please see Photo 1 recommended circuit, If has higher EMC request, please use Photo 2 recommended circuit. Specs as below
  1. MOV: recommend 14D-561K, to protect the module from damage when lightning surge.
  2. R1: 680KΩ/1W.
  3. CY1, CY2: 1000pF/400VAC.
  4. CX1: 0.22μF/275VAC.
  5. LCM: 25mH-35mH.

Note :

- 1.The product should be used under the specification range, otherwise it will cause permanent damage to it.
- 2.Product's input terminal should connect to fuse;
- 3.If the product is not worked under the load range(below the minimum load or beyond the load range), we cannot ensure that the performance of product is in accordance with all the indexes in this manual;
- 4.Unless otherwise specified, data in this datasheet are tested under conditions of Ta=25°C, humidity<75% when inputting nominal voltage and outputting rated load(pure resistance load);
- 5.All index testing methods in this datasheet are based on our Company's corporate standards
- 6.The performance indexes of the product models listed in this manual are as above, but some indexes of non-standard model products will exceed the above-mentioned requirements, please directly contact our technician for specific information;
- 7.We can provide customized product service;
- 8.The product specification may be changed at any time without prior notice.

**Guangzhou Aipu Electron Technology Co., Ltd**

Address: Building 4, HEDY Park, No.63, Punan Road, Huangpu Dist, Guangzhou, China.

Tel: 86-20-84206763 Fax: 86-20-84206762 HOTLINE: 400-889-8821

E-mail: sales@aipu-elec.com Website: www.aipupower.com